

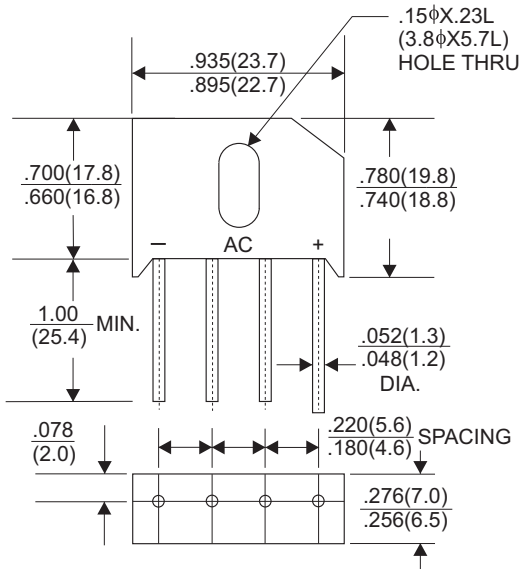

KBU401 THRU KBU407

SINGLE PHASE BRIDGE RECTIFIERS
Reverse Voltage - 50 to 1000 Volts Forward Current - 4.0 Ampere

KBU



Dimensions in inches and (millimeters)

FEATURES

- * Glass Passivated Die Construction
- * Low forward voltage drop
- * High current capability
- * High reliability
- * High surge current capability

MECHANICAL DATA

- * Case: Molded plastic
- * Epoxy: UL 94V-0 rate flame retardant
- * Lead: Axial leads, solderable per
- * Polarity: Color band denotes cathode end
- * Mounting position: Any

MAXIMUM RATINGS AND ELECTRICAL CHARACTERISTICS

Rating 25°C ambient temperature unless otherwise specified.
 Single phase half wave, 60Hz, resistive or inductive load.
 For capacitive load, derate current by 20%.

TYPE NUMBER	KBU401	KBU402	KBU403	KBU404	KBU405	KBU406	KBU407	UNITS	
Maximum Recurrent Peak Reverse Voltage	50	100	200	400	600	800	1000	V	
Maximum RMS Voltage	35	70	140	280	420	560	700	V	
Maximum DC Blocking Voltage	50	100	200	400	600	800	1000	V	
Maximum Average Forward Rectified Current									
.375"(9.5mm) Lead Length at Ta=40°C								4.0	A
Peak Forward Surge Current, 8.3 ms single half sine-wave superimposed on rated load (JEDEC method)								150	A
Maximum Forward Voltage Drop per Bridge Element at 4.0A D.C.								1.1	V
Maximum DC Reverse Current Ta=25°C								5	µA
at Rated DC Blocking Voltage Ta=100°C								200	µA
Operating Temperature Range, Tj								-65 — +150	°C
Storage Temperature Range, Tstg								-65 — +150	°C

RATING AND CHARACTERISTIC CURVES (KBU401 THRU KBU407)

FIG.1-TYPICAL FORWARD CURRENT DERATING CURVE

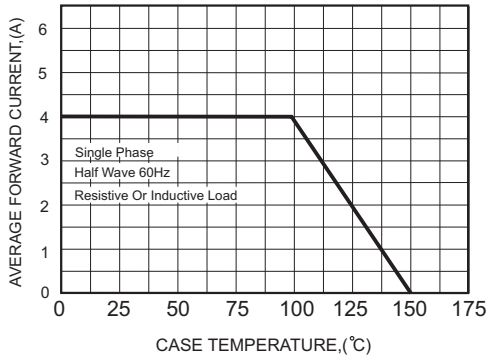

FIG.2-MAXIMUM NON-REPETITIVE FORWARD SURGE CURRENT

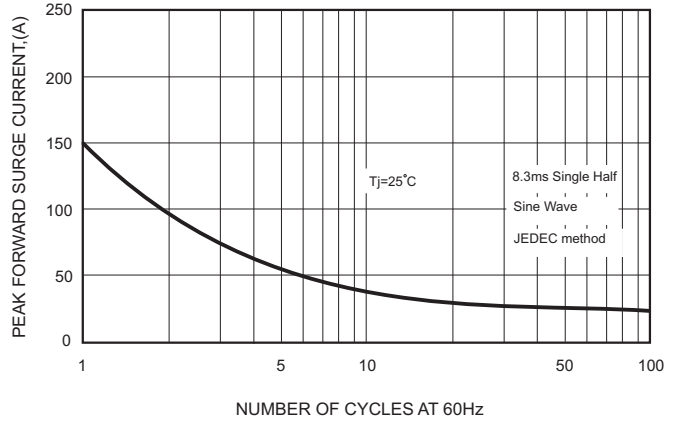

FIG.3-TYPICAL FORWARD CHARACTERISTICS

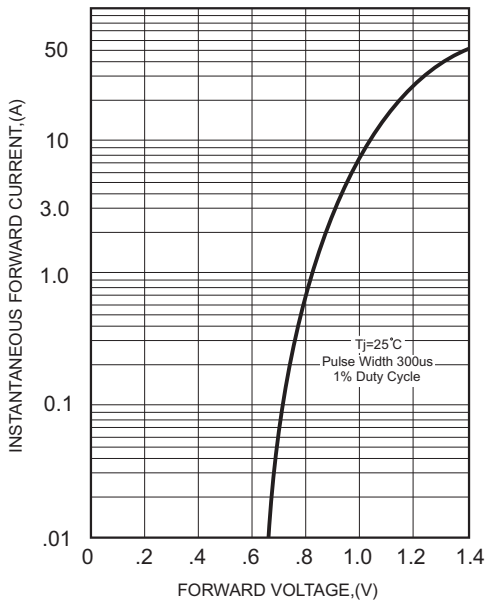

FIG.4-TYPICAL REVERSE CHARACTERISTICS

